

# 3D PRINTING DESIGN GUIDELINES



4DOITaly

This guide shows which are the guidelines that the 3D model .STL must have to be printed correctly in 4PRINT without incurring errors.

3D models must be closed correctly; all the surfaces must be joined in one, so as to generate a model without imperfections.

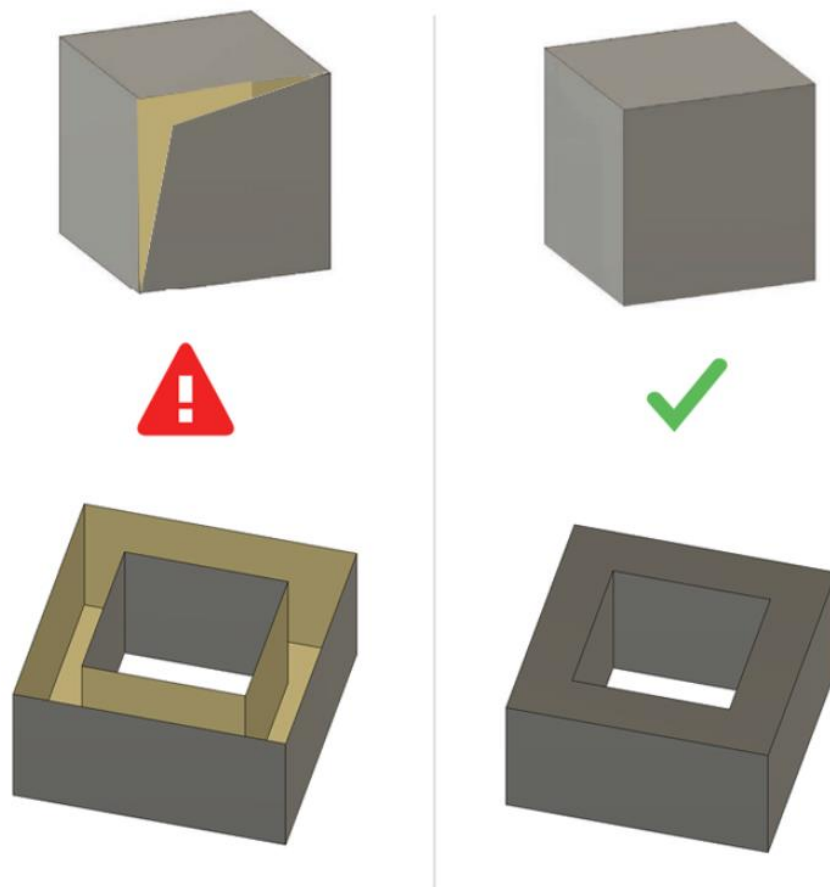

Minimum values	mm
Slit between walls	1mm
Printable feature or detail	1mm width/ thickness
Hole diameter	1mm
Shaft diameter	1mm
Printable font	12 pt
Clearance	1mm
Embossings/Debossings	1mm

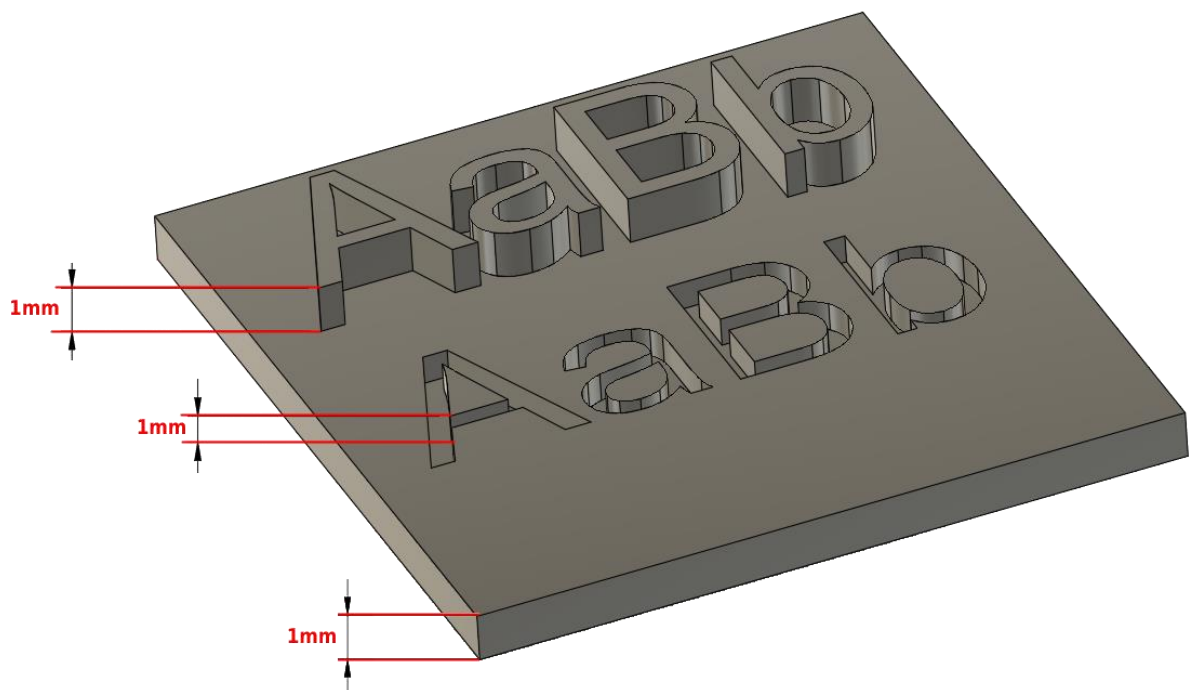
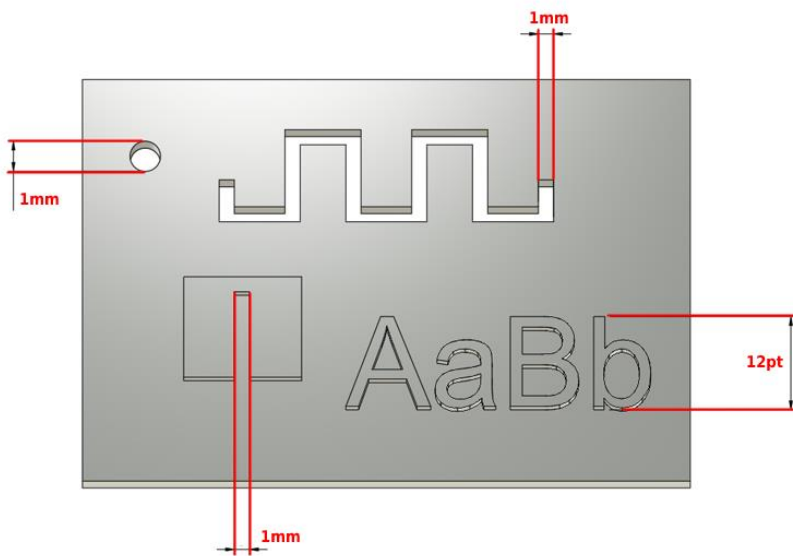

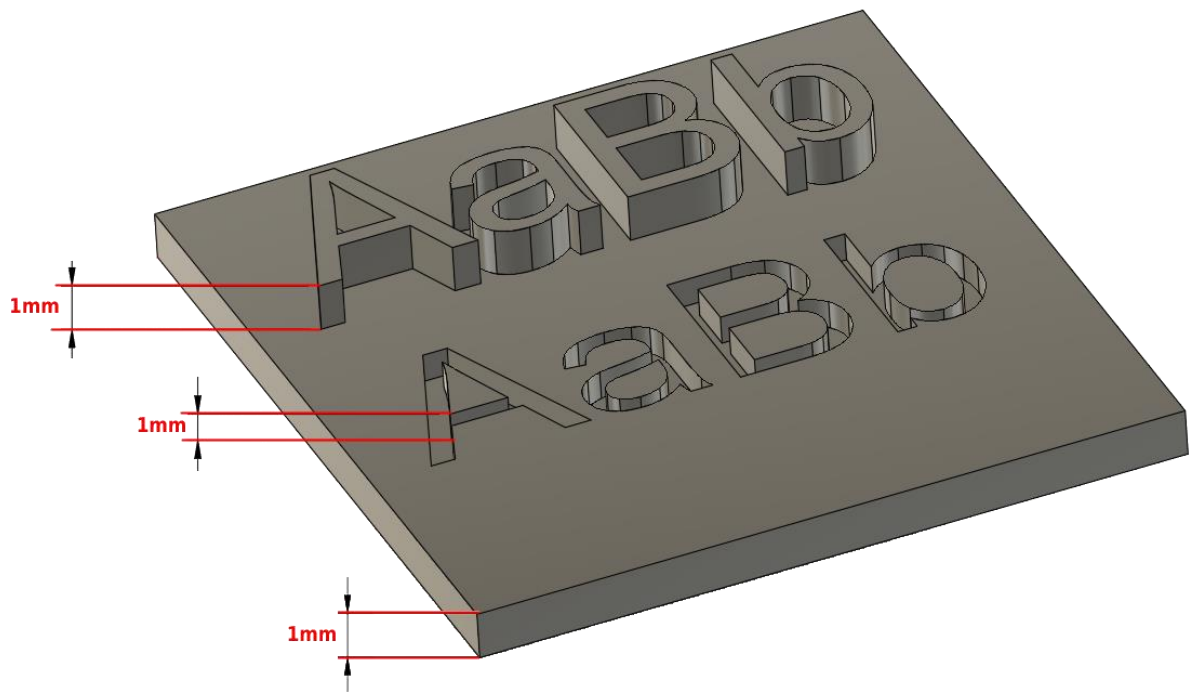
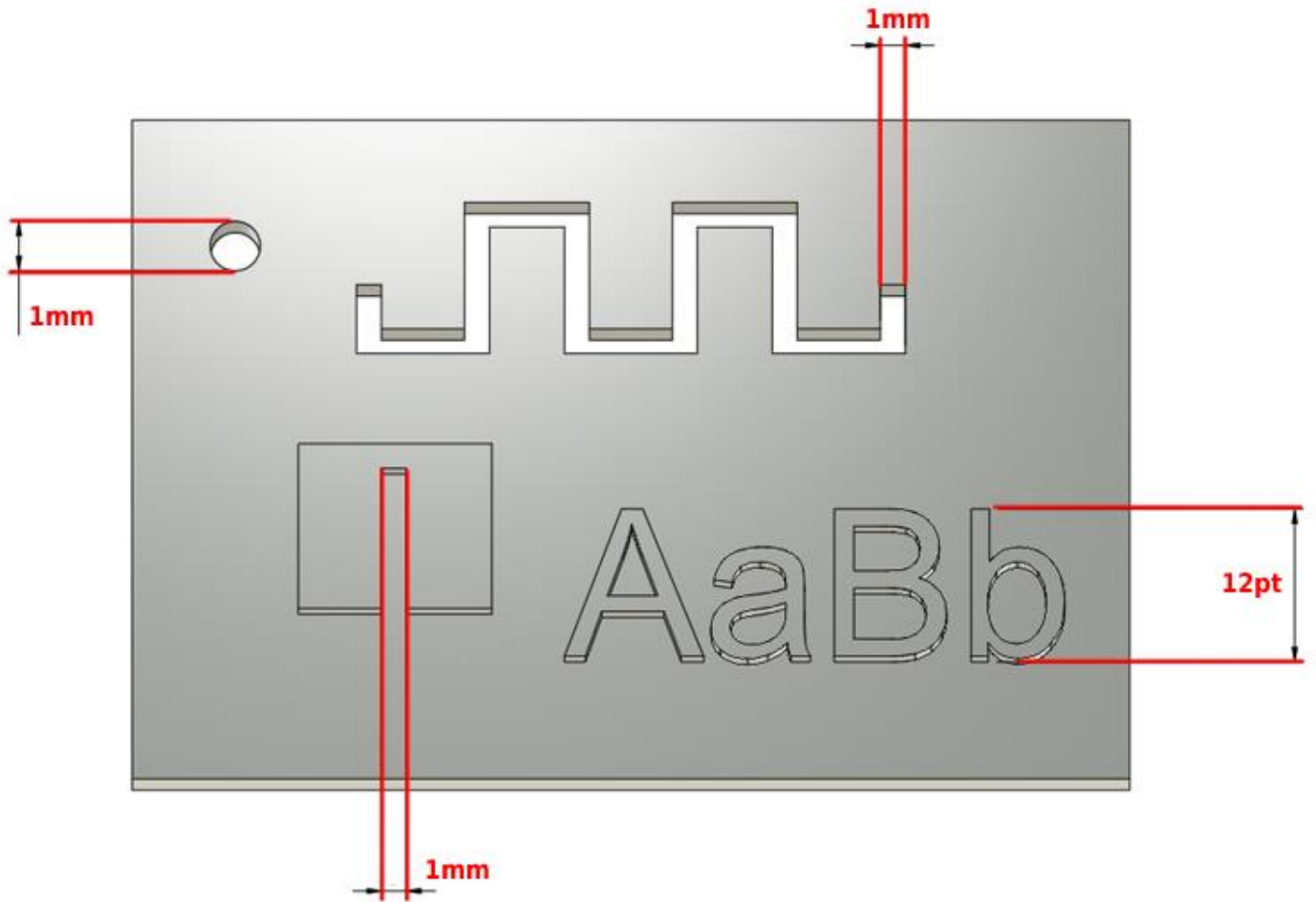



**4DOITaly**

## **RISORSE**

✉ [info@4doit.it](mailto:info@4doit.it)

☎ +39 3927753034

**P.IVA** 11755570014

**IBAN** IT21E0501801000000012457438

**SDI** 5RU082D (O=lettera)

📍 Via Bonzanigo 15 (TO)  
(Uffici) Previo Appuntamento